

CANOGA 193-GH SERIES

CONCRETE MIXER (GAS)

OPERATOR'S MANUAL



Revision 203	05.2011
Manual Part No. 166136	

Caution: Read all safety and operating instructions before using this equipment. This manual **MUST** accompany the equipment at all times.

CANOGA I93 SERIES CONCRETE MIXER

PAGE

SAFETY

NO.

- Safety Message/Alert Symbols
- Hazard Symbols
- Rules for Safe Operation
- Operation & Safety Decals

- 3
- 4
- 5-6
- 7

PRODUCT SPECIFICATIONS

- Mixer Specifications & Decal Locations
- Product Specifications
- Mixer Basic Components
- Basic Engine Components

- 8
- 9
- 10
- 11

INSPECTION & START-UP

- Pre-Inspection (Gasoline Engine)
- Initial Start-Up (Gasoline Engine)

- 12-13
- 14

OPERATION

- Concrete Mixing
- Operation
- Towing Guidelines
- Safety Chain Connection

- 15
- 16
- 17-18
- 19

MAINTENANCE & TROUBLESHOOTING

- Maintenance (Engine)
- Maintenance (Mixer)
- Troubleshooting (Mixer)

- 20-21
- 22-24
- 25

GENERAL PRODUCT INFORMATION

- Ordering Information
- Contact Information & Limited Warranty
- Certificate of Origin for a Vehicle Request Form

- 26
- 27
- 28

Safety precautions should be followed at all times when operating this equipment. Failure to read and understand the Safety Precaution and Operating Instructions could result in injury to yourself and others.

This Operation Manual has been developed to provide complete instructions for the safe and efficient operation of the Canoga 193-GH Series Concrete Mixer (Gas).

Before using these mixers, ensure that the person operating the mixer has read and understands all instructions in this manual.

SAFETY MESSAGE / ALERT SYMBOLS

A safety message alerts you to potential hazards that could hurt you or others. Each safety message is preceded by a safety alert symbol () and one of three words: **DANGER**, **WARNING**, or **CAUTION**.

DANGER

You **WILL** be **KILLED** or **SERIOUSLY INJURED** if you do not follow directions.

WARNING

You **CAN** be **KILLED** or **SERIOUSLY INJURED** if you do not follow directions.

CAUTION

You **CAN** be **INJURED** if you do not follow directions. It may also be used to alert against unsafe practices.

Each message tells you what the hazard is, what can happen, and what you can do to avoid or reduce injury. Other important messages are preceded by the word **NOTICE**.

NOTICE

You can cause **PROPERTY DAMAGE** to your machine if you don't follow directions.

The safety labels should be periodically inspected and cleaned by the user to maintain good legibility at a safe viewing distance. If the label is worn, damaged or illegible, it should be replaced.

Potential hazards associated with the Canoga 193-GH Series Concrete Mixer (Gas) operation will be referenced with Hazard Symbols which appear throughout this manual, and will be referenced in conjunction with Safety Message Alert Symbols.

HAZARD SYMBOLS



ALWAYS read this Owner's Manual before operating the machine.



Avoid inhalation of and skin contact with silica dust and/or mist.



ALWAYS place the power ON/OFF switch in the **OFF** position when the mixer is not in use.



ALWAYS wear approved eye protection.



ALWAYS wear approved ear protection.



ALWAYS wear approved respiratory protection.



NEVER operate equipment with covers, or guards removed. Keep fingers, hands, hair and clothing away from all moving parts to prevent injury.



Use caution around gears. Keep fingers, hands, hair and clothing away from all moving parts to prevent injury.



DO NOT touch hot engine components while the machine is running or immediately after operating.



NEVER operate the machine in an explosive atmosphere or near combustible materials.

RULES FOR SAFE OPERATION

DANGER

Failure to follow instructions in this manual may lead to serious injury or even death! This equipment is to be operated by trained and qualified personnel only! This equipment is for industrial use only.

The following safety guidelines should always be used when operating the Canoga 193-GH Concrete Mixer (Gas).

GENERAL SAFETY



- **DO NOT** operate or service this equipment before reading this entire manual.

- This equipment should not be operated by persons under 18 years of age.
- **NEVER** operate this equipment without proper protective clothing, shatterproof glasses, steeltoed boots and other protective devices required by the job.
- **NEVER** operate this equipment when not feeling well due to fatigue, illness or taking medicine.
- **NEVER** operate this equipment under the influence of drugs or alcohol.
- Whenever necessary, replace nameplate, operation and safety decals when they become difficult read.
- **ALWAYS** check the machine for loose bolts before starting.



- **ALWAYS** wear proper respiratory (mask), hearing and eye protection equipment when operating the mixer.

- **NEVER** place hands inside the drum while the drum is rotating.
- **ALWAYS** store equipment properly when it is not being used. Equipment should be stored in a clean, dry location out of the reach of children.



- **NEVER** leave the mixer unattended. Turn off gasoline engine when unattended.

- **CAUTION** must always be observed while servicing this mixer. Rotating parts can cause injury if contacted.
- This mixer is intended for the production of concrete. Mixer must be used only for its intended purpose.
- This mixer is not suitable for the mixing of flammable or explosive substances.



- **NEVER** operate the mixer in an explosive atmosphere.

- Before starting the mixer, check that all guards are in position and correctly fitted.
- Keep area around the mixer clear of obstructions and trip hazards which could cause persons to fall onto moving parts.
- **ALWAYS** ensure mixer is on level ground before mixing.
- Become familiar with the controls of the mixer before operating.

- Ensure the drum is rotating while filling and emptying the drum.
- **NEVER** disconnect any “emergency or safety devices”. These devices are intended for operator safety. Disconnection of these devices can cause severe injury, bodily harm or even death! Disconnection of any of these devices will void all warranties.
- Unauthorized equipment modifications will void all warranties. Manufacturer does not assume responsibility for any accident due to equipment modifications.

FUELING SAFETY

- Allow the engine to cool before adding fuel or performing service and maintenance functions. Contact with hot components can cause serious burns.
- **ALWAYS** refuel in a well-ventilated area, away from sparks and open flames.
- **ALWAYS** use extreme caution when working with flammable liquids. When refueling, stop the engine and allow it to cool. **DO NOT** smoke around or near the machine. Fire or explosion could result from fuel vapors, or if fuel is spilled on a hot engine.
- The engine of this mixer requires an adequate free flow of cooling air. **NEVER** operate the mixer in any enclosed or narrow area where free flow of the air is restricted. If the air flow is restricted it will cause serious damage to the mixer or engine and may cause injury to people and property. Remember the mixer’s engine (gasoline models only) gives off deadly gases.



- **NEVER** operate the mixer in an explosive atmosphere or near combustible materials. An explosion or fire could result causing severe bodily harm or even death.

Refer to the Engine Owner’s Manual for engine technical questions or information.

- **NEVER** use accessories or attachments, which are not recommended by Canoga for this equipment. Damage to the equipment and/or injury to user may result.

MAINTENANCE SAFETY

- **NEVER** lubricate components or attempt service on a running machine.
- Keep the machinery in proper running condition.
- Fix damage to the machine immediately and always replace broken parts or missing decals.

OPERATION & SAFETY DECALS

The Canoga Mixer is equipped with a number of safety decals (Figure 1) provided for operator safety and maintenance information. Should any of these decals become unreadable, replacements can be obtained by calling **(800) 262-1575**.

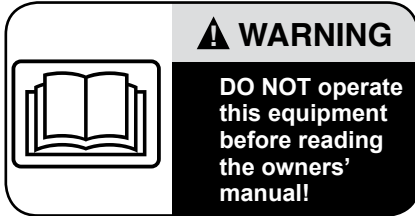

Decal A



Decal B

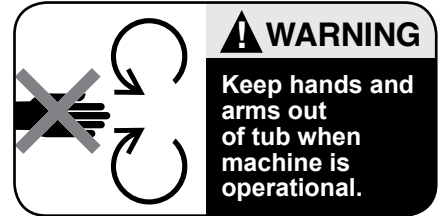

Decal C



Decal D



Decal E



Decal F

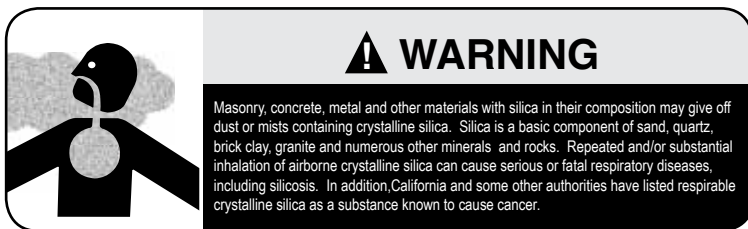

Decal G

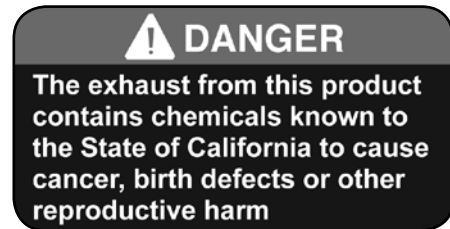

Decal H



Decal I

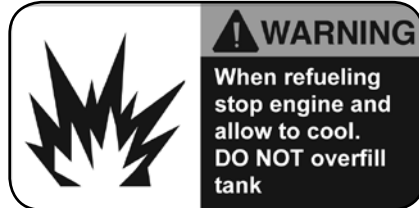

Decal J



Decal K



Decal L



Decal M

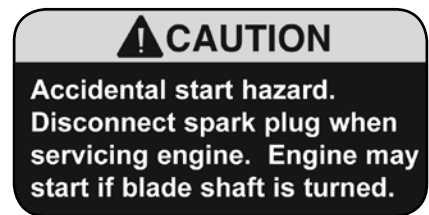

Decal N

Fig 1. Canoga I93-GH Safety Decal Sheet, Part No. I66008

MIXER SPECIFICATIONS & DECAL LOCATIONS

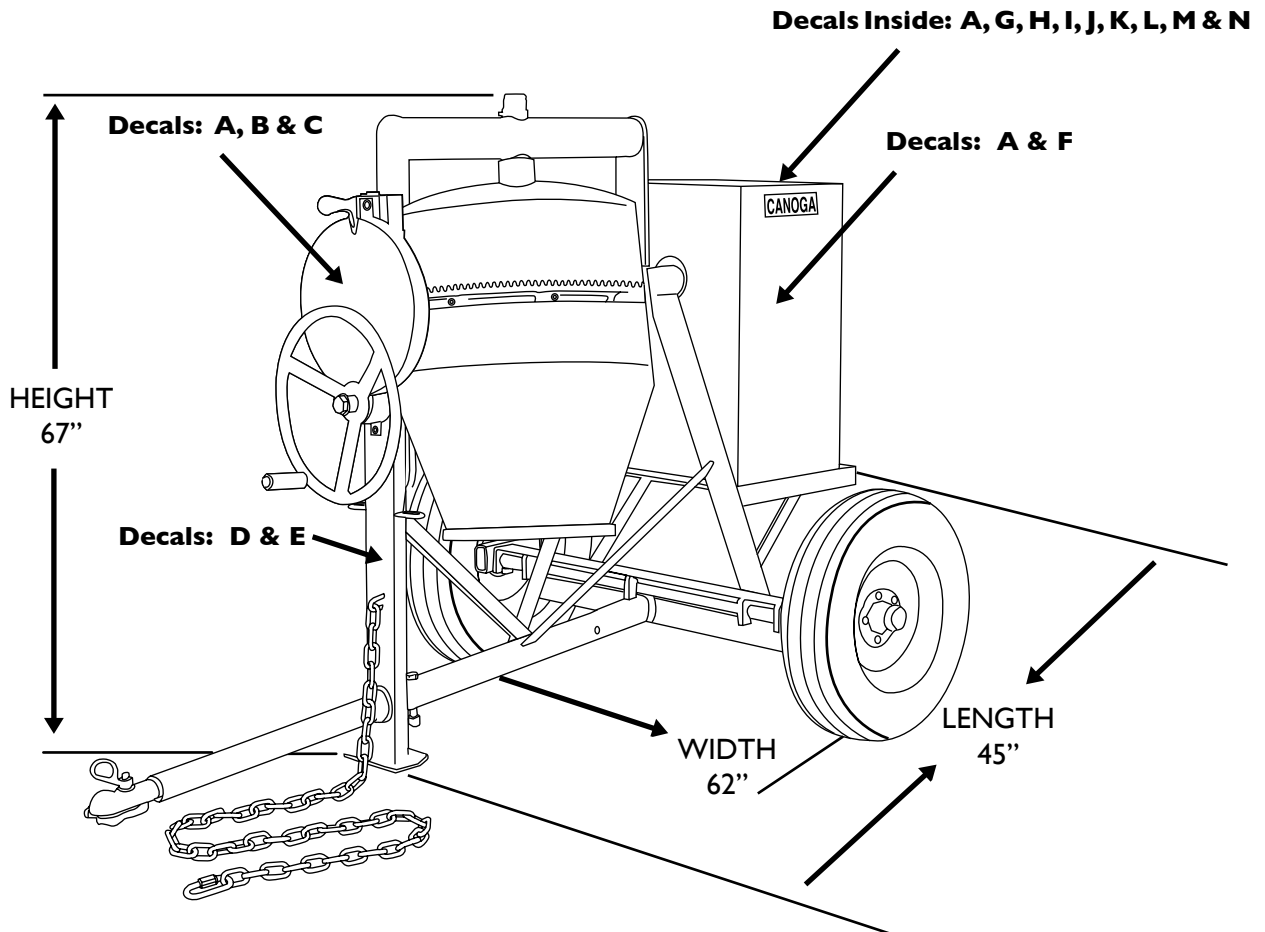

Fig 2. Mixer Dimensions and Decal Locations

Decal	Location	Description
A	Dump Gear Guard, Motor Side and Inside Motor Cabinet	Warning Read Manual Before Operating Equipment
B	Dump Gear Guard	Caution Guards in Place
C	Dump Gear Guard	Warning Keep Hands and Arms Out of Tub
D	Front Leg	Caution Fasten Safety Chain Before Towing
E	Front Leg	Warning Maintain Tire Pressure
F	Motor Side	Danger Use in Ventilated Areas
G	Inside Motor Cabinet	Warning Silica Dust Hazard
H	Inside Motor Cabinet	Danger Exhaust Contains Hazardous Chemicals
I	Inside Motor Cabinet	Service or Warranty Information
J	Inside Motor Cabinet	Warning Stop and Cool Before Refueling
K	Inside Motor Cabinet	Caution Do Not Touch Hot Surface
L	Inside Motor Cabinet	Notice Do Not Overtension Belts
M	Inside Motor Cabinet	Caution Keep Hands and Arm from Belt Drive
N	Inside Motor Cabinet	Caution Accidental Start Hazard

SPECIFICATIONS

Canoga I93-GH Specifications	
Model	I93-GH
Motor*	Gas
Horse Power	5-1/2 HP
Batch Capacity	1/2 to 3/4 Bag (5 cu. ft.)
Total Volume	8-1/2 cu.ft.
Drum Diameter	26"
Drum Depth	3/4"
Drum Opening	16"
Drive	Dual V-belts to cast gear
Axle	Torsion-Bar
Wheels	5.0 x 13"
Tires	ST175/80D 13C 6 ply Bias/Load Range C
Dimension (L x W X H)	95" x 62" x 67"
Shipping Weight	705 lbs.
Part Number	163822

* See engine manual for complete engine specifications.

MIXER BASIC COMPONENTS

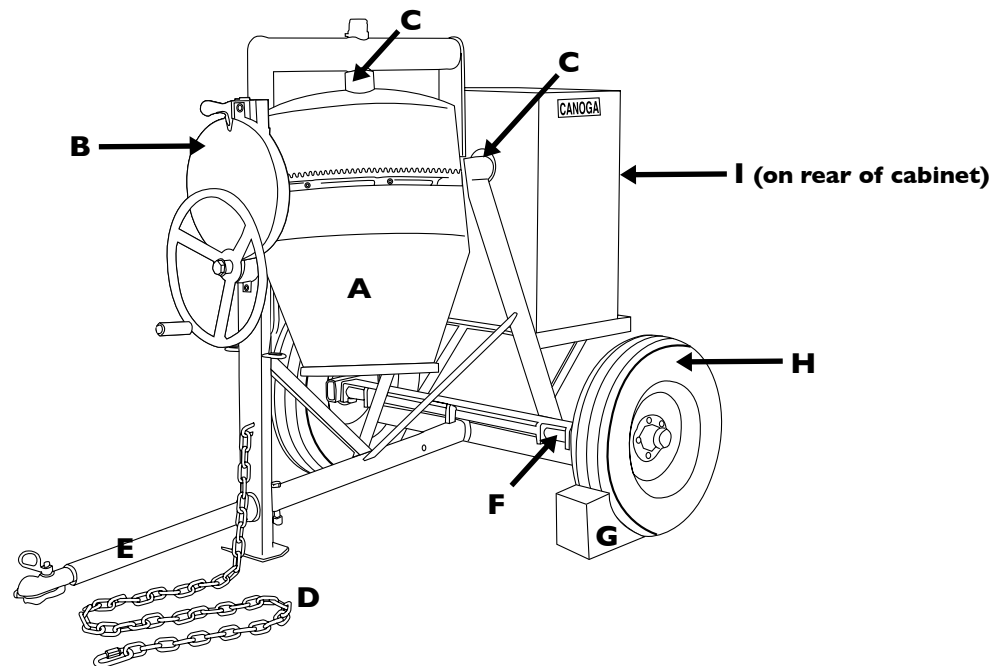

Fig 3. Mixer Major Components

- A. **Steel Mixing Drum** – The Canoga concrete mixer uses an 8-1/2 cu. ft. steel mixing drum. This drum is to be used for mixing of concrete. Always clean the drum after each use.
- B. **Dump Gear Guard** – **NEVER** remove the guarding on the dump guard.
- C. **Zerk Fittings** – Zerk fittings are located at the top of the engine side of the yoke and center of the drum bearing. Lubricate these fittings as referenced in the maintenance section of this manual.
- D. **Safety Chain** – This mixer uses a 3/16-inch thick, 72-inches long zinc-plated safety chain. **ALWAYS** connect the safety chain when towing.
- E. **Tow Bar** – This mixer uses various towing bars. Reference the tow bar drawing on page 9 to determine which tow bar meets your requirements.
- F. **Torsion Bar Suspension** – This mixer has a torsion bar suspension that should be inspected periodically.
- G. **Chock Blocks** – Place these blocks (not included as part of the mixer package) under each mixer wheel to prevent rolling, when mixer is not connected to the towing vehicle.
- H. **Tires Ply** – The tire ply (layers) number is rated in letters. This mixer uses 13-inch 2-ply tires. Replace with only recommended type tires.
- I. **Cabinet/Latch** – Encloses gas engine. **NEVER** run mixer with cabinet removed. Use latches to secure motor compartment cabinet.

BASIC ENGINE COMPONENTS

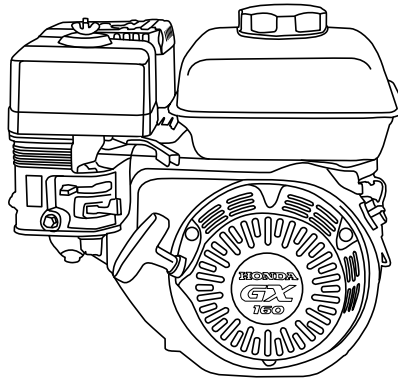

Fig 4. Honda CX Series Engine

INITIAL SERVICING

The engine (Figure 4) must be checked for proper lubrication and filled with fuel prior to operation. Refer to the manufacturer's engine manual for instructions and details of operation and servicing.

1. **Fuel Filler Cap** – Remove this cap to add unleaded gasoline to the fuel tank. Make sure cap is tightened securely. **DO NOT** over fill.



WARNING

Adding fuel to the tank should be accomplished only when the engine is stopped and has had an opportunity to cool down. In the event of a fuel spill, **DO NOT** attempt to start the engine until the fuel residue has been completely wiped up, and the area surrounding the engine is dry.

2. **Throttle Lever** – Used to adjust engine RPM speed (lever advanced forward **SLOW**, lever back toward operator **FAST**).
3. **Engine ON/OFF Switch** – ON position permits engine starting, OFF position stops engine operations.
4. **Recoil Starter (pull rope)** – Manual-starting method. Pull the starter grip until resistance is felt, then pull briskly and smoothly.
5. **Fuel Valve Lever** – **OPEN** to let fuel flow, **CLOSE** to stop the flow of fuel.
6. **Choke Lever** – Used in the starting of a cold engine, or in cold weather conditions. The choke enriches the fuel mixture.
7. **Air Cleaner** – Prevents dirt and other debris from entering the fuel system. Remove wing-nut on top of air filter canister to gain access to filter element.



NOTICE: Operating the engine without an air filter, with a damaged air filter, or a filter in need of replacement will allow dirt to enter the engine, causing rapid engine wear.

8. **Spark Plug** – Provides spark to the ignition system. Set spark plug gap to 0.6 - 0.7 mm (0.028 - 0.031 inch). Clean spark plug once a week.
9. **Muffler** – Used to reduce noise and emissions.



WARNING

Engine components can generate extreme heat. To prevent burns, **DO NOT** touch these areas while the engine is running or immediately after operating. **NEVER** operate the engine with the muffler removed.

10. **Fuel Tank** – Holds unleaded gasoline. For additional information refer to engine owner's manual.

PRE-INSPECTION (GAS ENGINE)

1. Before starting, read safety instructions at the beginning of this manual and the engine manual.
2. Clean the mixer, removing dirt and dust, particularly the engine cooling air inlet, carburetor and air cleaner.
3. Check the air filter for dirt and dust. If air filter is dirty, replace air filter with a new one as required.
4. Check carburetor for external dirt and dust. Clean with dry compressed air.
5. Check fastening nuts and bolts for tightness.

Engine Oil Check - Refer to Engine manual for detailed instructions.

1. To check the engine oil level, place the mixer on secure level ground with the engine stopped.
2. Remove the filler dipstick from the engine oil filler hole (Figure 5) and wipe it clean.

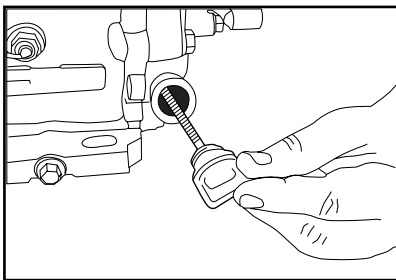

Fig 5. Engine Oil Dipstick (Removed)

3. Insert and remove the dipstick without screwing it into the filler neck. Check the oil level shown on the dipstick.
4. If the engine oil level is low (Figure 6), fill to the edge of the oil filler hole with the recommended oil type listed in the table below.

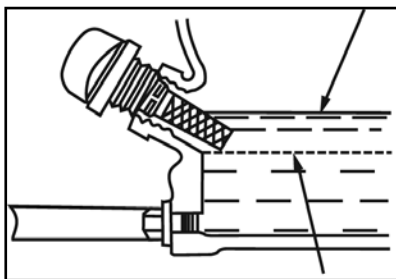

Fig 6. Engine Oil Dipstick (Oil Level)

Engine Oil Type		
SEASON	TEMPERATURE	OIL TYPE
Summer	25°C or Higher	SAE 10W-30
Spring/Fall	25°C ~ 10°C	SAE 10W- 30/20
Winter	0°C or Lower	SAE 20W-10

PRE-INSPECTION (GAS ENGINE)

**EXPLOSIVE FUEL****Fuel Check**

If your mixer has a gasoline engine, determine if the engine fuel is low. If fuel is low, remove the fuel filler cap and fill with unleaded gasoline. Motor fuels are highly flammable and can be dangerous if mishandled. **DO NOT** smoke while refueling. **DO NOT** attempt to refuel the trowel if the engine is hot or running.

1. Remove gasoline cap located on top of fuel tank.
2. Visually inspect to see if fuel level is low. If fuel is low, replenish with unleaded fuel.
3. When refueling, be sure to use a strainer for filtration. **DO NOT** top-off fuel. Wipe up any spilled fuel.

V-Belt Check

A worn or damaged V-belt can adversely affect the performance of the mixer. If a V-belt is defective or worn simply replace the V-belt as outlined in the maintenance section of this manual.

Blade Check

Check for worn blades. If using a steel tub and the blades are worn, replace the entire tub assembly. Remember the blades are welded to tub. If using a plastic tub, replace the blades using the part numbers referenced in the parts section of manual.

Start/Stop Switches

This mixer has been equipped with start/stop switches for turning the engine off. This switch should be in the **STOP** position when the mixer is not in use.

Grease Fittings (Zerk)

Check the zerk grease fittings (Figure 18) as shown in the maintenance section of manual.

INITIAL START-UP (GAS ENGINE)

The following steps outline the procedure for starting the engine. Depending on the type of engine employed in the mixer the steps may vary slightly.

1. Move the fuel shut-off lever (Figure 7) to the **ON** position.
2. To start a cold engine, move the choke lever (Figure 8) to the **CLOSED** position.

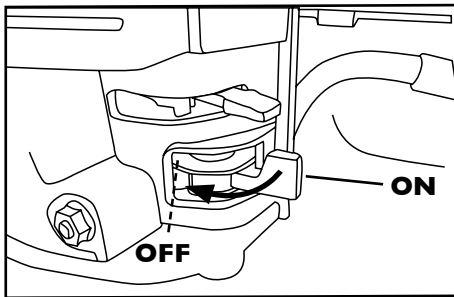

Fig 7. Fuel Shut-OFF Lever

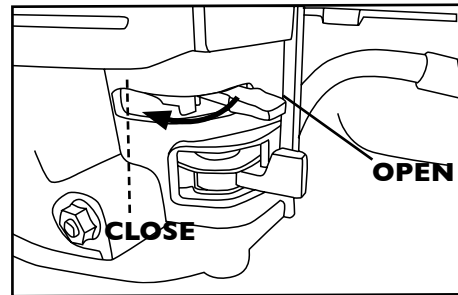

Fig 8. Choke Lever

3. Move the throttle lever (Figure 9) away from the slow position, about 1/3 of the way toward the fast position.
4. Turn the engine switch (Figure 10) to the **ON** position.

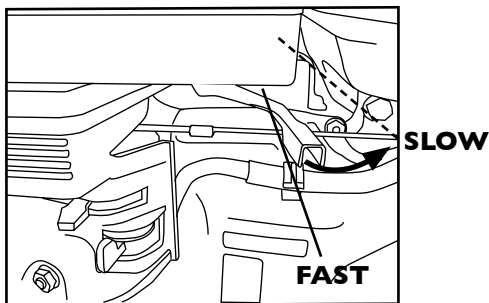

Fig 9. Throttle Lever

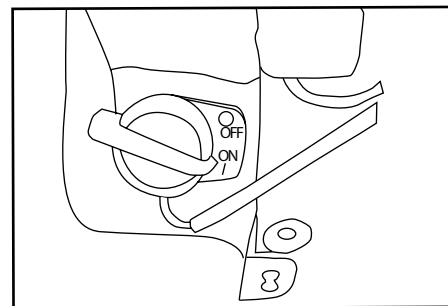

Fig 10. Engine ON/OFF Switch

5. Pull the starter grip (Figure 11) lightly until you feel resistance, then pull briskly. The drum should begin to rotate at this time.

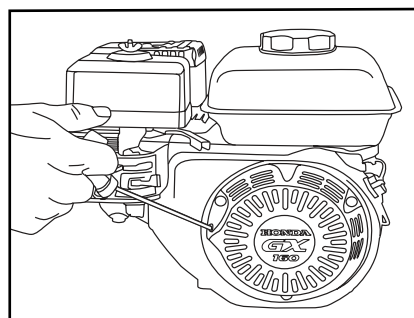

Fig 11. Starter Grip

CONCRETE MIXING

Application

This mixer is **only** intended for the production of cement concrete. The mixer must be used for its intended purpose and is not suitable for the mixing of flammable or explosive substances. The mixer must not be used in an explosive atmosphere. Refer to the reference table below when mixing concrete for various applications.

Concrete Mixing Hints

APPLICATIONS	MIX RATIOS	BATCH QUANTITIES					APPROX. BATCH OUTPUT	
		CEMENT 12lbs. (50 Kgs.) Bag	SAND		STONE		CU. FT.	LTR
			CU. FT.	LTR	CU. FT.	LTR		
Most Ordinary	1:2:4	1/2 BAG	1-1/4	35	2-1/2	71	3	85
Foundations	1:3:6	1/3 BAG	1-1/4	35	2-1/2	71	2-3/4	78
Rough Mass Concrete	1:4:8	1/4 BAG	1-1/4	35	2-1/2	71	2-3/4	78
Watertight Floors, Tanks, Pits, Etc.	1:1-1/2:3	2/3 BAG	1-1/4	35	3	71	3	85

OPERATION

1. To position the drum, make sure the mixer is placed on firm level ground, then pull up on the dump latch (Figure 12) and turn the hand wheel until the drum is at the desired position. Once the drum is at the desired position, pull down on the dump latch to lock the drum in position.

**CAUTION**

NEVER stand in front or behind the mixing drum while it is being placed in the dump position. Stay clear of the mixing drum while it is being positioned.

2. As the drum rotates, use a shovel (Figure 13) to place the cement mix inside the drum, add water as required.
3. Placing the shovel all the way inside the drum will cause the shovel to strike the blades. This condition could cause injury to personnel. **NEVER** place hands inside the mixing drum while it is rotating (Figure 14).

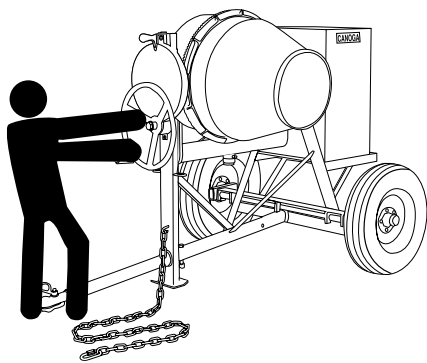

Fig 12. Mixing Drum Positioning

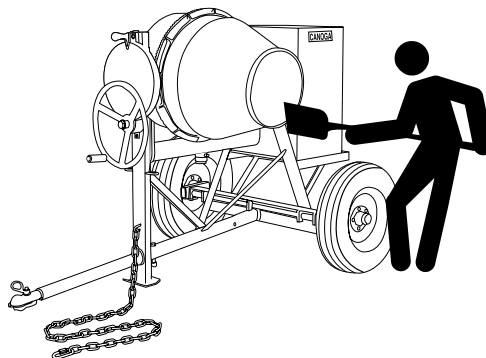

Fig 13. Filling Mixing Drum



Fig 14. Filling Mixing Drum

Stopping the Mixer

1. Turn the main **start/stop** switch to the **STOP** position.
2. Push the fuel shut-off lever to the **OFF** position.
3. Clear drum of all debris and foreign matter.

TOWING GUIDELINES



CAUTION

Check with your county or state safety towing regulations department before towing your mixer.

To reduce the possibility of an accident while transporting the mixer on public roads, always make sure that the mixer towing components and the towing vehicle are in good operating condition and both units are mechanically sound.

The following list of suggestions should be used when towing the mixer

- Make sure that the hitch and coupling of the towing vehicle are rated equal to, or greater than the trailer “gross vehicle weight rating” (GVWR).



CAUTION

If the mixer tow bar is deformed or damaged replace entire tow bar. **NEVER** tow the mixer with a defective tow bar. There exists the possibility of the trailer separating from the towing vehicle.

- **ALWAYS** inspect the hitch and coupling for wear. **NEVER** tow the mixer with defective hitches, couplings, chains etc.
- **CHECK** the tire air pressure on both the towing vehicle and the trailer. Also check the tire tread wear on both vehicles.
- **ALWAYS** make sure the mixer is equipped with a “Safety Chain”.
- **ALWAYS** attach trailer’s safety chain to the frame of towing vehicle.
- **ALWAYS** make sure that the towing vehicle’s directional, backup, and brake lights are working properly.
- Remember in most cases the maximum speed unless otherwise posted for highway towing is 45 MPH, however before towing your mixer, check your local state, and county vehicle towing requirements. Recommended off-road towing is not to exceed **10 MPH** or less depending on type of terrain.
- When towing of the mixer is required, place the drum in the **DOWN** position (mouth facing **DOWN**).
- **ALWAYS** make sure that the fuel valve lever is in the **OFF** position.
- Check wheel mounting lug nuts with a torque wrench. Torque wheel lug nuts as described in the maintenance section of this manual.
- Avoid sudden stops and starts. This can cause skidding, or jackknifing.
- Avoid sharp turns to prevent rolling.

TOWING GUIDELINES CONTINUED

Tow Bar to Vehicle Connection (Coupler Only)

1. Check the vehicle hitch ball, and mixer's coupler for signs of wear or damage. Replace any parts that are worn or damaged before towing.
2. Use only a 2-inch ball diameter (towing vehicle), this will match the mixer's 2-inch coupler. Use of any other ball diameter will create an extremely dangerous condition which can result in separation of the coupler and ball or ball failure.
3. After tow bar has been connected to mixer, attach mixer's coupler to the hitch ball on the towing vehicle securely and make sure the lock lever is in tight.

Mixer Tow Bar Vehicle Connection (Pintle & Loop)

1. Make sure the bumper on the towing vehicle is equipped to handle either a pintle or loop type tow bar configuration.
2. After tow bar has been connected to mixer, secure either type of tow bar to the towing vehicle, following state and county towing regulations.
3. As a minimum, use a 1/2-inch bolt and nylock nut grade 5 when securing either tow bar to the towing vehicle.

SAFETY CHAIN CONNECTION



CAUTION

NEVER tow the mixer with the safety chain removed. The safety chain is intended to prevent complete separation of the mixer from the towing vehicle in the event of a tow bar failure. Reference the figure below for the installation of the Safety Chain.

Tow Bar to Mixer Connection

1. Insert the tow bar through the round opening at the bottom of the mixer stand. Align the hole on the tow bar with the hole on the mixer frame, and insert 1/2-inch bolt through tow bar and frame. Secure tow bar to frame with 1/2-inch nylock nut. Tighten to 40 ft.-lbs.
2. Route the safety chain through the holes just above the tow bar, located on each side of the mixer stand. Loop the chain together and place under the tow bar. Secure the loop with the connector link.
3. Extend the safety chain along the length of the tow bar, looping it through the tow bar's connector link. Remove any excess chain slack.
4. Connect the free end of the safety chain (clevis safety hook) to the towing vehicle. **Remember it is critical that the length of the chain be properly adjusted**, to prevent the draw bar and the front of the mixer stand from dropping to the the ground (contact) in the event the draw bar becomes disconnected from the towing vehicle.

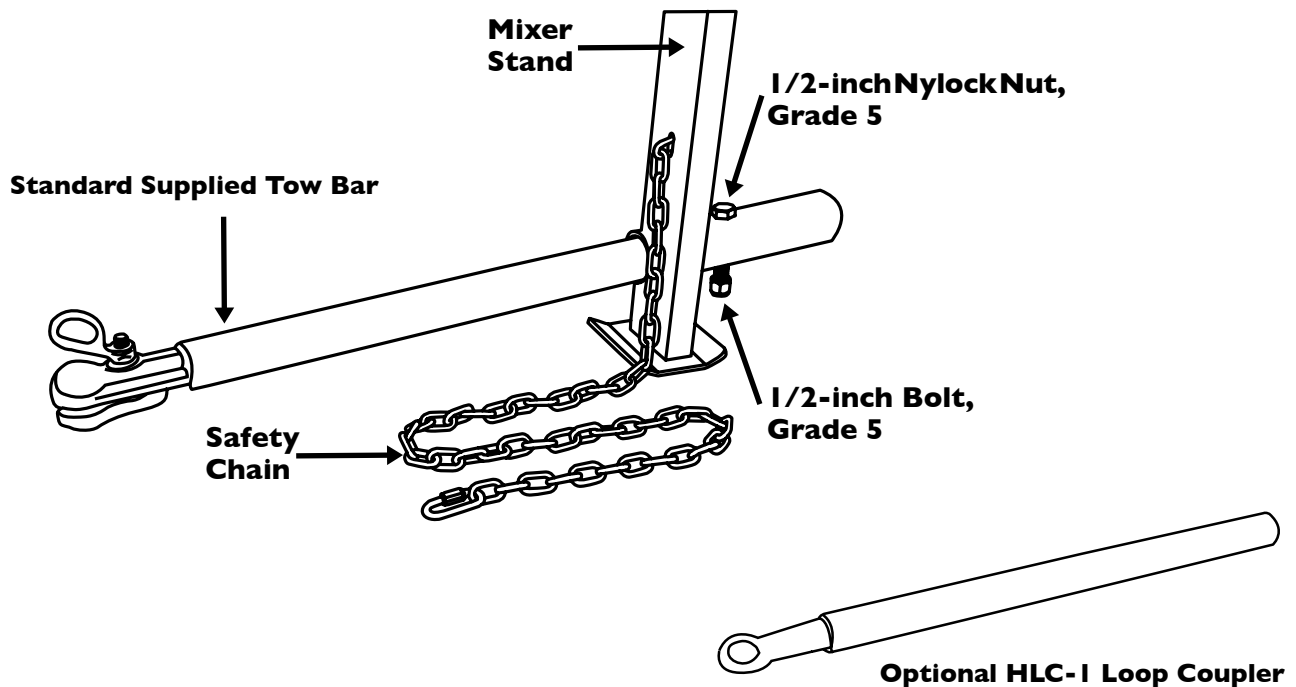

Fig 15. Tow Bar and Safety Chain Installation

ENGINE MAINTENANCE

Use this table as a general maintenance guideline when servicing your engine. For more detail engine maintenance information, refer to the engine owner’s manual supplied with your engine.

Engine Maintenance Schedule							
DESCRIPTION (3)	OPERATION	BEFORE	FIRST MONTH OR 10 HRS.	EVERY 3 MONTHS OR 25 HRS.	EVERY 6 MONTHS OR 50 HRS.	EVERY YEAR OR 100 HRS.	EVERY 2 YEARS OR 200 HRS.
Engine Oil	CHECK	X					
	CHANGE		X				
Air Cleaner	CHECK	X					
	CHANGE			X (1)			
All Nuts & Bolts	Re-tighten if necessary	X					
Spark Plug	CHECK-CLEAN				X		
	REPLACE						X
Fuel Tank	CLEAN					X	

- (1) Service more frequently when used in DUSTY areas.
- (2) These items should be serviced by your service dealer, unless you have the proper tools and are mechanically proficient. Refer to the HONDA or ROBIN Shop Manual for service procedures.
- (3) For commercial use, log hours of operation to determine proper maintenance intervals.

ENGINE MAINTENANCE

Perform the scheduled maintenance procedures as defined by the previous table and below:

DAILY

- Thoroughly remove dirt and oil from the engine and control area. Clean or replace the air cleaner elements as necessary. Check and retighten all fasteners as necessary. Check the gearbox for oil leaks. Repair or replace as needed.

WEEKLY

- Remove the fuel filter cap and clean the inside of the fuel tank.

ENGINE OIL

1. Drain the engine oil when the oil is warm as shown (Figure 16).
2. Remove the oil drain bolt and sealing washer and allow the oil to drain into a suitable container.
3. Replace engine oil with recommended type oil as listed in the Engine Oil Type table. **DO NOT** overfill.
4. Install drain bolt with sealing washer and tighten securely.



DANGER

DO NOT use gasoline as a cleaning solvent, because that would create a risk of fire or explosion.

ENGINE AIR CLEANER

1. Remove the air cleaner cover and foam filter element as shown (Figure 17).
2. Tap the paper filter element several times on a hard surface to remove dirt, or blow compressed air [not exceeding 30 psi (207 kPa, 2.1 kgf/cm²)] through the filter element from the air cleaner case side. **NEVER** brush off dirt. Brushing will force dirt into the fibers. Replace the paper filter element if it is excessively dirty.
3. Clean foam element in warm, soapy water or nonflammable solvent. Rinse and dry thoroughly. Dip the element in clean engine oil and completely squeeze out the excess oil from the element before installing.

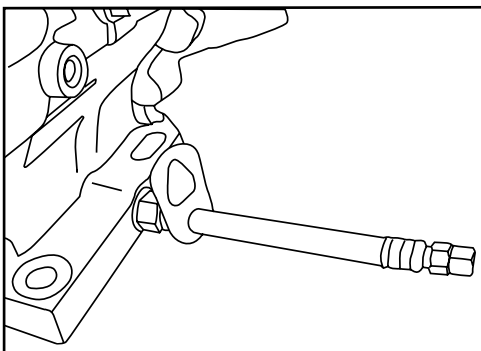

Fig 16. Engine Oil (Draining)

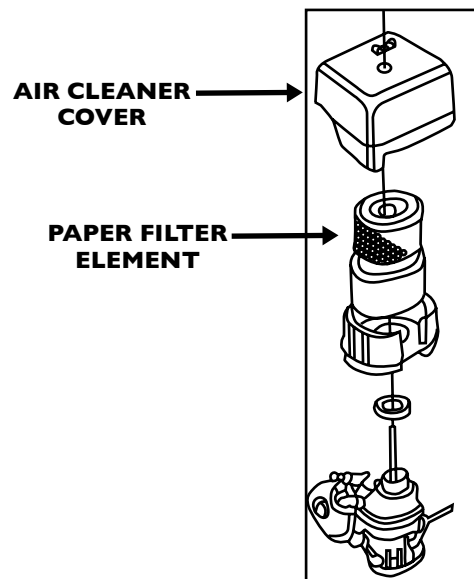

Fig 17. Engine Air Cleaner

MIXER MAINTENANCE

Ball Socket and Clamp Face Maintenance

1. If the towing vehicle is equipped with a ball socket, smear socket periodically with multi-purpose grease. This will keep the ball socket well lubricated.
2. When parking or storing your mixer. Keep the coupler off the ground so dirt will not build up in the ball socket.

Grease Fittings (Zerk) Maintenance (Mixer)

There are 2 grease fittings (Figure 18) that will require lubrication. Lubricate these fittings once a week. Use lithium base grease, grade No.1.

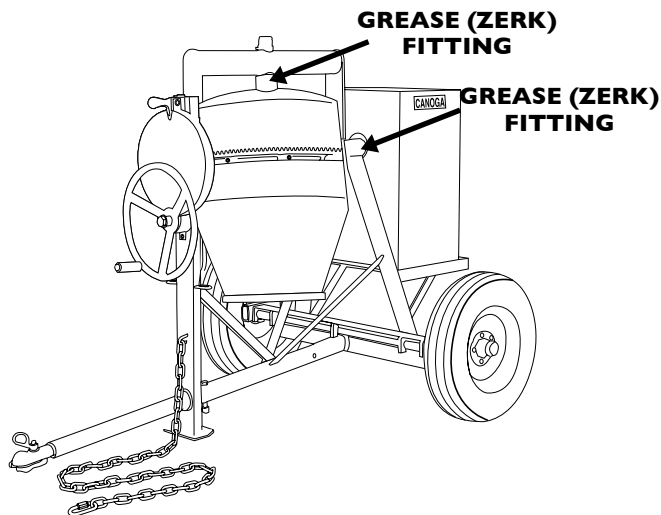

Fig 18. Grease Fittings Mixer

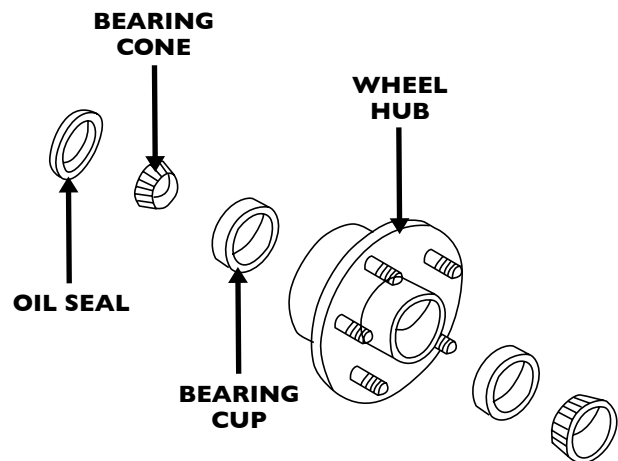

Fig 19. Wheel Hub and Bearings

Wheel Bearings

1. After every 3 months of operation, remove the hub dust cap and inspect the wheel bearings (Figure 19). Once a year, or when required, disassemble the wheel hubs remove the old grease and repack the bearings forcing grease between rollers, cone and cage with a good grade of high speed wheel bearing grease (**never** use grease heavier than 265 A.S.T.M. penetration ("No. 2."))

Fill the wheel hub (Figure 19) with grease to the inside diameter of the outer races and also fill the hub grease cap. Reassemble the hub and mount the wheel. Then tighten the adjusting nut, at the same time turn the wheel in both directions, until there is a slight bind to be sure all the bearing surfaces are in contact.

Then back-off the adjusting nut 1/6 to 1/4 turn or to the nearest locking hole or sufficiently to allow the wheel to rotate freely within limits of .001" to .010" end play. Lock the nut at this position. Install the cotter pin and dust cap, and tighten all hardware.

Mixer Cleaning

1. **Always** wash drum out after each use.
2. **NEVER** pour or spray water over the gas engine.

MIXER MAINTENANCE

Tires/Wheels/Lug Nuts

Tires and wheels are a very important and critical components of the trailer. When specifying or replacing the trailer wheels it is important the wheels, tires, and axle are properly matched.



CAUTION

DO NOT attempt to repair or modify a wheel. **DO NOT** install an inter-tube to correct a leak through the rim. If the rim is cracked, the air pressure in the inter-tube may cause pieces of the rim to explode (break-off) with great force and can cause serious eye or bodily injury.

Tire Wear/Inflation







Tire inflation pressure is the most important factor in tire life. Pressure should be checked cold before operation. **DO NOT** bleed air from tires when they are hot. Check inflation pressure weekly during use to insure the maximum tire life and tread wear.

The Tire Wear Troubleshooting table will help pinpoint the causes and solutions of tire wear problems.



CAUTION

NOTE: ALWAYS wear safety glasses when removing or installing force fitted parts. Failure to comply may result in serious injury.

Tire Wear Troubleshooting			
WEAR PATTERN		CAUSE	SOLUTION
	Center Wear	Over inflation	Adjust pressure to particular load per the manufacturer.
	Edge Wear	Under inflation	Adjust pressure to particular load per the manufacturer.
	Side Wear	Loss of chamber or overloading	Make sure load does not exceed axle rating. Align wheels.
	Toe Wear	Incorrect toe-in	Align wheels.
	Cupping	Out-of-balance	Check bearing adjustment and balance tires.
	Flat Spots	Wheel lockup & tire skidding	Avoid sudden stops when possible and adjust brakes.

MIXER MAINTENANCE

Lug Nut Torque Requirements

It is extremely important to apply and maintain proper wheel mounting torque on the trailer. Be sure to use only the fasteners matched to the cone angle of the wheel. Proper procedure for attachment of the wheels is as follows:

NOTICE

NEVER use an pneumatic air gun (Figure 20) to tighten wheel lug nuts.

1. Start all wheel lug nuts by hand using a Torque Wrench (Figure 21).
2. Torque all lug nuts in sequence (Figure 22). **DO NOT** torque the wheel lug nuts all the way down.
3. Tighten each lug nut in 3 separate passes as defined by Troubleshooting table. After first road use, retorque all lug nuts in sequence. Check all wheel lug nuts periodically.

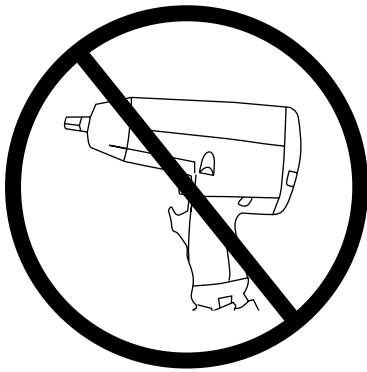

Fig 20. Pneumatic Air Gun

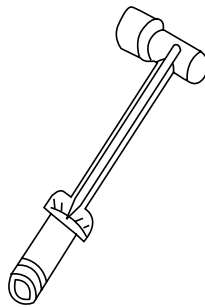

Fig 21. Torque Wrench

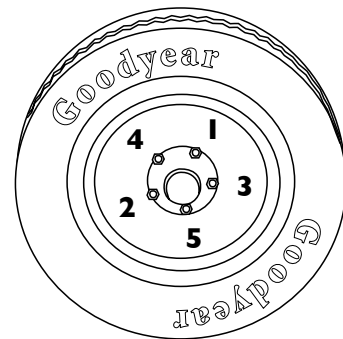

Fig 22. Wheel Lug Nuts Tightening Sequence

Mixer Storage

For storage of the mixer for over 30 days, the following is recommended:

- Drain the fuel tank completely, or add STA-BIL to the fuel.
- Run the engine until the fuel is completely consumed.
- Completely drain used oil from the engine crankcase and fill with fresh clean oil, then follow the procedures described in the engine manual for engine storage.
- Clean the entire mixer and engine compartment.
- Place the mixing drum in the down position (mouth facing downward).
- Cover the mixer and place it a clean dry area, that is protected from harsh elements.

TROUBLESHOOTING

Practically all breakdowns can be prevented by proper handling and maintenance inspections, but in the event of a breakdown, please take a remedial action following the diagnosis based on the Troubleshooting information shown below. If the problem cannot be remedied, please leave the unit just as it is and consult our company's business office or service center.

Mixer Troubleshooting		
SYMPTOM	POSSIBLE PROBLEM	SOLUTION
Drum rotates rough	Defective ring gear?	Check that the ring gear and bearings are not worn. Replace as necessary.
	Defective pinion gear?	Check that the pinion gear and bearings are not worn. Replace as necessary.
	Worn V-belt?	Replace V-Belt.
	Loose pulley?	Tighten or replace pulley.
Drum does not rotate at all	Fuel?	Check level of fuel in fuel tank. Add fuel if necessary. Make sure fuel is being supplied to the engine. Check to ensure that the fuel filter is not clogged.
	Broken V-belt?	Replace V-belt.
	Defective ring or pinion gears?	Check that the gears and bearings are not broken. Replace as necessary.

ACCESSORIES, ORDERING AND RETURN INFORMATION

Ordering Information

You may order MK Diamond products through your local MK Diamond distributor or, you may order direct from MK Diamond.

NOTE: There is a \$25.00 minimum order when ordering direct from MK Diamond. All purchases must be made using VISA or MasterCard.

When ordering direct from MK Diamond, please have the following information ready before calling:

- The Model of the machine
- The Serial Number of the machine
- Where the machine was purchased and when
- The Part Number for the part(s) being ordered
- The Part Description for the part(s) being ordered

All parts may be ordered by calling toll free to **(800) 421-5830** or **(310) 539-5221** and asking for Customer Service. For technical questions, call **(800) 474-5594** or **(310) 257-2845**.

Return Materials Policy

To expedite the service relative to the return of a product purchased through MK Diamond, please observe the following:

NOTE: When returning items, they must have been purchased within the previous twelve (12) months.

- Have the Model Number of the machine
- Have the Serial Number of the machine
- Have the location of where the machine was purchased and when
- Contact Customer Service for approval to return the item(s)
- Follow the packaging instructions in the following section
- Ensure your item(s) are prepaid to the destination

For returned items, call toll free to **(800) 421-5830** or **(310) 539-5221** and asking for Customer Service. For technical questions, call **(800) 474-5594** or **(310) 257-2845**.

Packaging Instructions

- Remove the blade guard.
- Dry the machine before shipping.
- Package the unit in its original container or one of comparable size (do not ship the unit partially exposed)
- Ensure all parts are secured in the packaging to prevent moving

Authorized Service Centers

For quicker repair time, you may contact MK Diamond Customer Service, toll free at **(800) 421-5830** or **(310) 539-5221** for the Authorized Service Center closest to you. For technical questions, call **(800) 474-5594**.

CONTACT

Canoga Equipment is a subsidiary of MK Diamond Products, Inc. Please contact MK Diamond Customer Service with any questions you might have regarding distributors, parts or service.

Telephone: **(800) 421-5830**

Fax: **(310) 539-5158**

E-mail: **Customer_Service@MKDiamond.com**

Customer Service Hours: **Monday through Friday, 6AM-5PM PST**

**MK Diamond Products, Inc.
1315 Storm Parkway
Torrance, CA 90501**

CANOGA LIMITED WARRANTY

MK DIAMOND PRODUCTS, INC. will guarantee every CANOGA® machine they build, to be free from defects in material and workmanship for (1) one year from date of purchase. The obligation of MK DIAMOND PRODUCTS, INC. under this warranty is limited to the repair or replacement of any parts which, under normal use, prove to be defective in material or workmanship. The parts involved or the unit in question should be returned to MK DIAMOND PRODUCTS, INC. or to a point designated by us, transportation prepaid.

This warranty does not obligate us to bear the cost of labor or transportation charges in connection with replacement or repair of defective parts. Likewise, it shall NOT apply to any unit which has been subjected to misuse, neglect or accident. This warranty does NOT apply to any machine which has been repaired or altered outside our factory.

This warranty does NOT obligate MK DIAMOND PRODUCTS, INC., with respect to items not of our manufacture, such as engines, motors, hydraulics, etc., which are subject to their own guarantees and warranties.

We shall in no event be liable for consequential damages or contingent liabilities arising out of failure of any equipment or parts to operate properly.

© COPYRIGHT 2010, CANOGA EQUIPMENT. ALL RIGHTS RESERVED.

The Canoga logo is a registered trademark of Canoga Equipment and may not be used, reproduced, or altered without written permission. All other trademarks are the property of their respective owners and used with permission.

Canoga Equipment may have patents, patent applications, trade marks, copyrights of other intellectual property right covering this product in this document.

This manual **MUST** accompany the equipment at all times. This manual is considered a permanent part of the equipment and should remain with the unit if resold.

The information and specifications included in this publication were in effect at the time of approval for printing. Illustrations are based on the Model 193 Concrete Mixer. Illustrations, descriptions, references and technical data contained in this manual are for guidance only and may not be considered as binding. Canoga reserves the right to discontinue or change specifications, design or the information published in this publication at any time without notice and without incurring any obligations.



Certificate of Origin for a Vehicle Request Form

Check with your county or state for towing regulations before towing your Canoga mixer. If you require a Certificate of Origin for a Vehicle for your Canoga mixer, please fill out the form and Canoga will send the necessary paper work to your distributor for them to issue your Certificate.

Manufacturer's Certificate of Origin form may also be found online at http://canogamixers.com/vehicle_cert.html

PERSONAL INFORMATION

First Name	Last Name
Company	Address
Address 2	City
State	Zip Code
Email Address	Phone

DISTRIBUTOR INFORMATION

Name	Address
City	State
Zip Code	

CANOGA INFORMATION

Model Number	Part Number
Serial Number	Invoice Number
Date Purchased	

Please return the completed form via email, fax or mail. Forms that are not fully completed cannot be processed.

Fax: (310) 530-3695

Mail: Canoga Products
Customer Service
1315 Storm Parkway
Torrance, CA 90509